

Balancers for Lipol/Lion packs **BLCR 4F, BLCR 4FC** (Version 2.50 and higher)

Processor Balancers BLCR 4FC are designed for quality, reliable and easy balancing of 2 up to 12 cells in battery packs (Lipol / Li-Ion / Li-Ion A123 systems). **BLCR 4F** is simpler type, has not communication connector, no possible connect to serial, no possible communication with PC. Other features are the same.

They may be used with chargers based on both – direct current and also pulse charging currents. They are processor controlled and are calibrated in manufacture therefore need no additional setting using trimmers etc. Cells are balanced shortly after connecting the balancer to the cells. Great advantage of this approach compared to "voltage limiters" is that cells may be balance if charging is finished early (e.g. cells are charged to 70% and you need to start flying immediately). Another big advantage is the possibility to charge cells with currents much higher than currents which balancer can balance. The main advantage however is that the cells are truly balanced which cannot be ensured by "voltage limiters" in principal. Thanks to processor, balancers identify defective, damaged or undercharged cells and inform the user of such situation acoustically and by LED. If voltage of one or all connected cells exceeds (from any reason, defective or incorrectly set charger, too high charging currents etc) 4.25V/cell or other (user set) voltage, balancer will not allow another increase of voltage and informs of this acoustically and by LED. In this case it is also possible to make use of automatic disconnection of charger and thus save cells from destroy.

BLCR 4F, BLCR 4FC balancers work not only with chargers for Lipol cells, but also with sources of constant current. However, the use of constant current source is an emergency solution (low charging currents) it is applicable.

Example of battery pack with power conductors, connectors MP JET 2.5 and a service connector SCA_4:

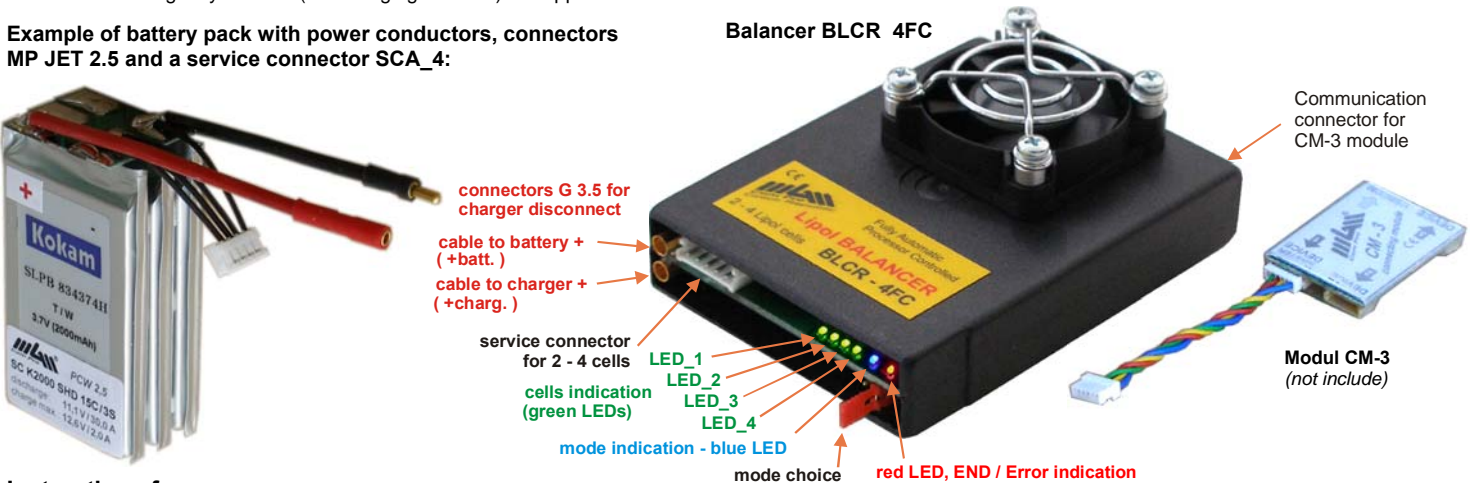

Instructions for use:

Battery pack that should be balanced must be equipped with a service connector "SCA_3" up to "SCA_5", (battery pack with service connector may be ordered already completed or each part separately and soldered to any battery pack by yourself). If your battery pack is equipped with different than MGM compro service connector, make a reducing part, for example from "SET_06" (see page 5 of this manual).

If you wish to charge and balance more than 4 cells in serial it is necessary to use more BLCR 4FC balancers (also possible to combine with BLCR 5FC) and a connection module CM-3. Balancers are connected to CM-3 using CC_05 cables (cables and module CM-3 is not a part of the package).

Connection to PC is done using CC_03 cable connected to module CM-3 and USBCOM+ (USBCOM+ version 2.12 and higher)

If you wish to connect only one balancer to PC (without CM-3 module) use the balancer and USBCOM+ and CC_04 cable.

How to connect balancer to battery pack:

Connect the battery pack that you wish to charge and balance to the charger, set a suitable charging mode and start charging. Then connect the battery pack using service cable with "SCA_3" up to "SCA_5" to balancer. If programming jumper "mode choice" is plugged in, end / switching off voltage of cells may be set (for details see page 4 - "End / switching off voltage setting"):

- | | | |
|-----------------------------|--|-------------------------------|
| a) standard Lipol (default) | – charging Lipol to 4.20 V (ensured by charger) | / safety switch off on 4.25 V |
| b) constant current Lipol | – charging Lipol to 4.18 V (ensured by charger) | / safety switch off on 4.20 V |
| c) standard Li-Ion | – charging Li-Ion to 4.10 V (ensured by charger) | / safety switch off on 4.15 V |
| d) Li-Ion „A123 systems“ | – charging Li-Ion to 3.60 V (ensured by charger) | / safety switch off on 3.65 V |

If the switching off (end) voltage is exceeded from any reasons, acoustical and LED signalization is activated, as well as "automatic safety disconnection of the cells". This applies when the cells are connected using „+ batt.“ a „+ charg.“ connectors, see page (page 3).

If the programming jumper (mode choice) is not plugged in, balancer starts its operation with previously set end / switching off voltage. Immediately after battery is connected balancer testing and blinking by all the LEDs. Shortly after it balancer signals number of connected cells by number of beeps (for check) and using lit up **green LED 1 to LED 4** shows connected cells which voltage is in allowed limits. Cells that do not fall into the limits are signaled by blinking of the corresponding **green LED**. If voltage of any cell is lower than 2V, **LED** corresponding to this cell is not lit up. All **LEDs** are turned off after ca 5s, and start blinking which signals the start of balancing. If the overall voltage of the connected cells is <6V balancer works (to voltage ca 3.5V) but does not balance and is waiting for the overall voltage to rise above 6V - till then it beeps / blinks. If the charging current is not higher than maximal balancing current of the balancer, the battery pack is balanced quickly and even if the charging is finished early the battery pack is balanced.

Technical data BLCR 4F, BLCR 4FC:

temperature of the environment	0°C up to 40°C
compatible chargers:	any charger designed for Lipol, charging direct current or pulse eventually source of constant current up to 1A max. 25V
dimensions [mm]:	90x68x30
weight:	80 g
number of balanced Li-Ion / Li-Pol cells:	2 – 4
maximal balancing current (short time):	2A (3A)
maximal charging current (depends on differences in cells):	up to ~8A
accuracy of balancing (typical):	± 6mV
accuracy of balancing with balancers connected together, BLCR 4FC only (typical):	± 12 mV
serial connection of balancers, BLCR 4FC only:	max. 3 units (max. 12 Lipol cells)
overcharging signalization (charger failure, not suitable settings etc):	yes
charger disconnection when overcharging:	yes
max. current of disconnection circuit (between connectors "charg" and "batt"):	8A / 22mΩ
maximal voltage setting:	3.65 V / 4.15V / 4.20V / 4.25V
balancer connection to PC, BLCR 4FC only:	using USBCOM+ module, version 2.12 and higher
mutual connection of balancers	CM-3 module and CC_05 cables
balancing state indication:	by intensity of brightness of particular LEDs
state and error states indication:	LED and/or BEEP
error states	- voltage of cell < 2V / voltage of cells between 2V and 2.95V - disconnected cell, overall voltage < 6V

Appearance and technical data may change without prior notice

Balancing more than 4 cell (up to 12 cells) – connecting balancers in serial:

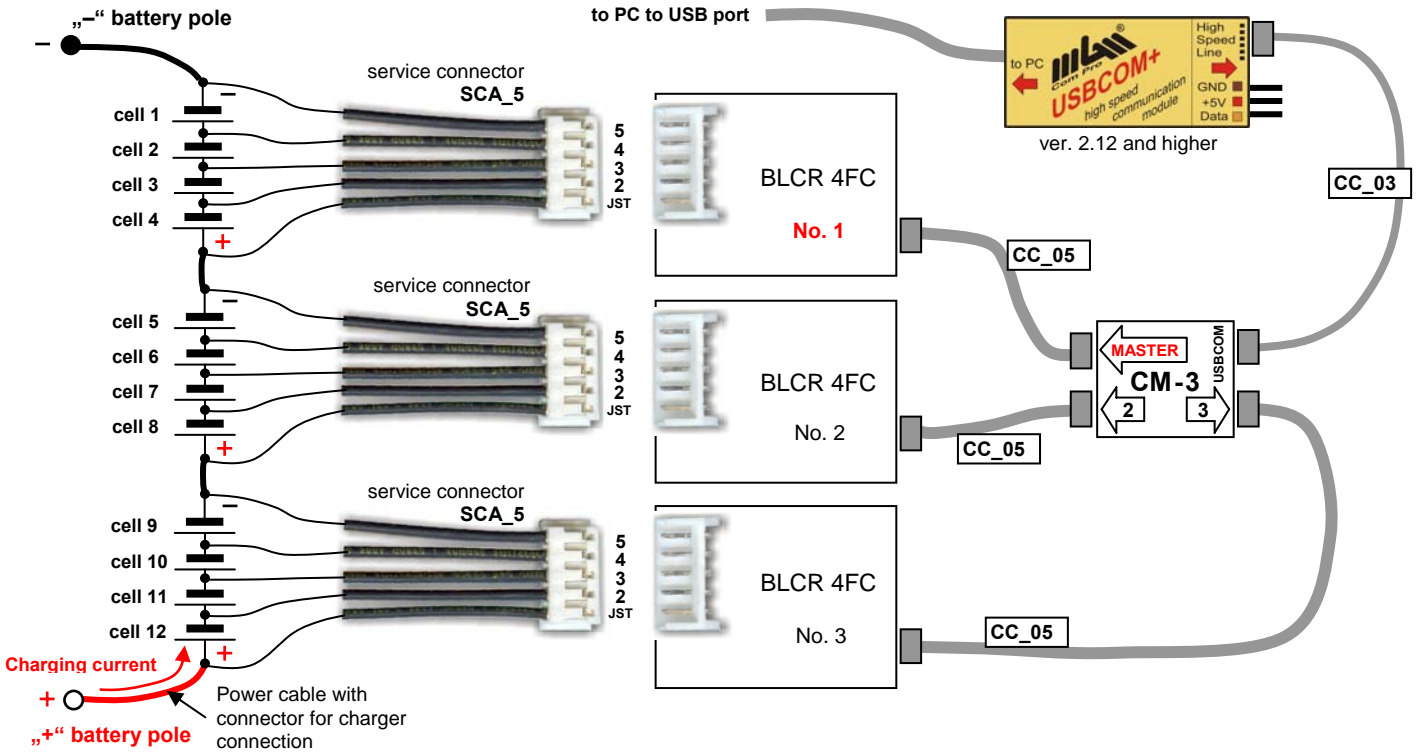

Service connectors of the accupack must be **divided between the cells so that at least 2 cells are connected to each balancer**.
 If you have cells **2S** up to **4S** use service connector **SCA 3, 4 or 5** and a 5pin connector **SCA 5** on the balancer.
Balancer that is connected to the "–" pole of the battery (No.1) must be connected using cable CC_05 to the "MASTER" position in the CM-3 module and must be connected to the battery using service connector SCA_5 (no.1) as first one ! Then, balancers No. 2 possibly No. 3 are connected to the service connectors of other cells.

!!! If balancers BLCR 5FC are combined with BLCR 4FC (version 2,50 and higher) you can used any type as MASTER (No.1). Balancers No. 2 and No. 3 (SLAVE) automatically take setting of balancer No. 1 (MASTER) !!!

- 1) Run "Charge Monitor" application on your PC (it is similar for chargers AQCB -xFC and balancers BLCR – 4FC and BLCR – 5FC). Application is installed automatically, see manual "Automatic_Instalation_Charge Monitor Application_280506.pdf". For details on how to control the program see "XXXXXX" (on CD or on www.mgm-compro.com). Use stated or newer versions of these manuals and applications.
- 2) Connect USBCOM+ module to USB port of your computer and connect it with CM-3 module using CC_03 cable.
- 3) Connect the cells for charging to the charger and start charging (*when using automatic disconnection function this will be done at the end !*)
- 4) Connect balancer No.1 using cable CC_05 to "MASTER" position on module CM-3. Connect cells 1 to 4 of the battery pack you wish to balance to this balancer using service connector **SCA_x** (No.1). Soon, voltages of these cells will appear in graph on screen.
- 5) Connect balancer No. 2 using cable CC_05 to "SLAVE 1" position on module CM-3. Connect cells 5 to 8 to this balancer using service connector **SCA_x** (No.2). Soon, voltages of these cells will appear in graph on screen.
- 6) Connect balancer No. 3 using cable CC_05 to "SLAVE 2" position on module CM-3. Connect cells 9 to 12 to this balancer using service connector **SCA_x** (No.3). Soon, voltages of these cells will appear in graph on screen.

If you do not wish to watch the balancing state on the screen of your PC, skip running the program and connecting CM-3 module to USBCOM+. Start with 3).

Example of charging / balancing 12 Lipol cells.

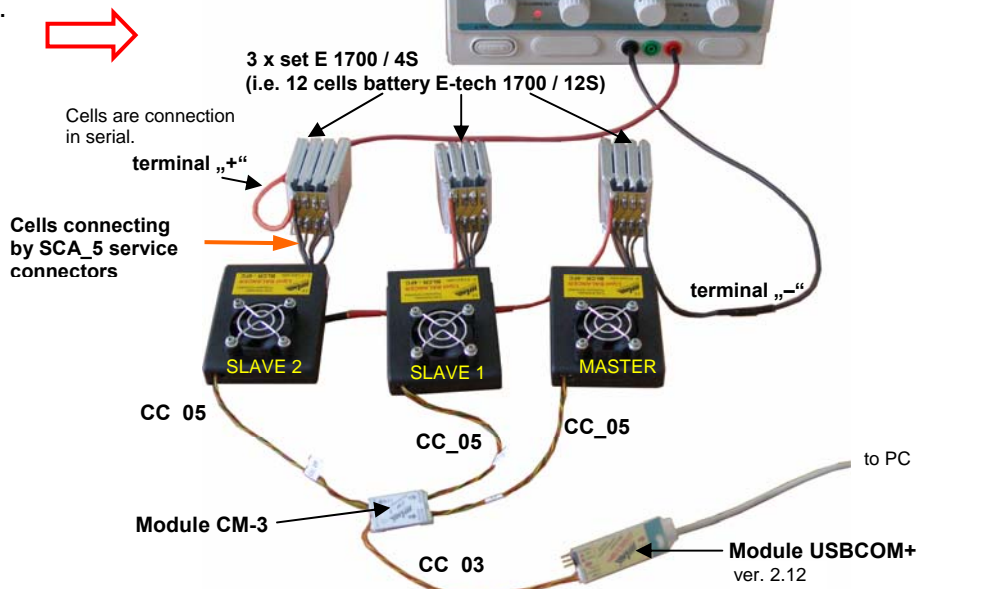

How to connect balancer to PC: (2 up to 4 cells):

If you wish to connect only one balancer to PC it is done using cable CC_04 (be careful not to interchange the ends of the cable – end marked as "BAL" or "BLCR xxx" must plugged into balancer !!!, not the other way).

- 1) Run "Charge Monitor" application on your PC (it is similar for chargers AQCB -xFC and balancers BLCR – 4FC and BLCR – 5FC). Application is installed automatically, see manual "Automatic_Instalation_Charge Monitor Application_280506.pdf". For details on how to control the program see "How to control Charge Monitor application Dddmmyy " (on CD or on www.mgm-compro.com). Use stated or newer versions of these manuals and applications.
- 2) Connect USBCOM+ module (version 2.12 and higher) to USB port of your computer and connect balancer using cable CC_04. The connection can also be done using cable CC_05 to module CM-3 (into MASTER port) and from CM-3 module to USBCOM+ using cable CC_03 (as if connecting more balancers).
- 3) Connect the cells for charging to the charger and start charging (when using automatic disconnection function this will be done in the end !)
- 4) Connect the cells for balancing to balancer BLCR 4FC using service connector – you may watch the balancing process on the screen.

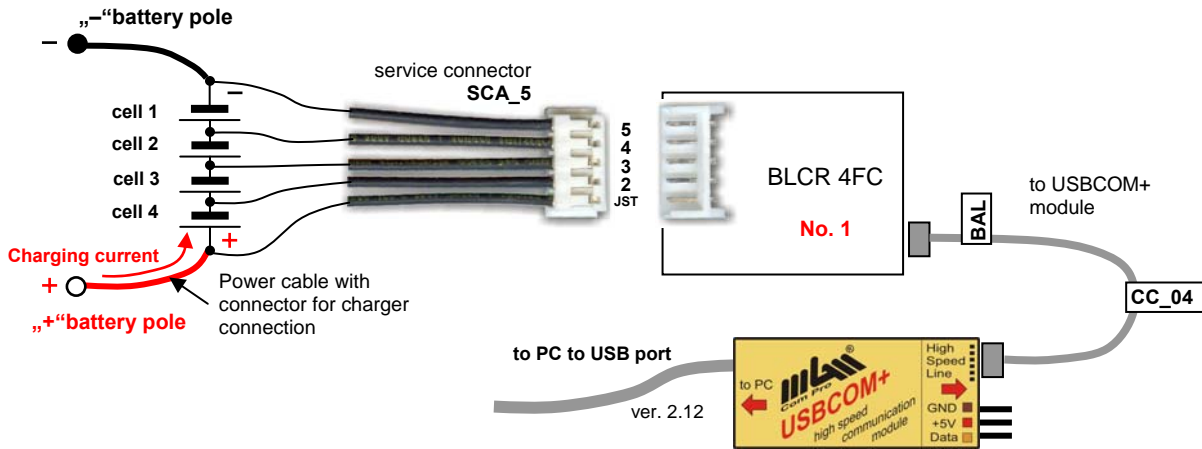

Notice: if the balancer is connected to PC or other balancers using CM-3 module, in between blinking of indication LEDs of particular cells (green), LED of cells 2. 3. 4 and ERR blink. Thus a mutual communication between balancers and/or communication with PC is indicated.

! Automatic safety disconnection of cells !

If you wish to use the Function "automatic safety disconnection of cells" from the charger in case of its failure or incorrect setting, it is necessary to connect disconnecting contact of the balancer between the charger and the charged cell – see figure below. Balancer is thus able to disconnect the plus pole of the charged battery from the charger. **When using this function it is necessary to first connect the cells to the balancer (balancers) and only then start charging (balancer without feeding is not able to transmit charging current through the disconnecting contact).**

For this function it is necessary to use balancer connected to cells that are connected with the "+" pole of the whole battery (highest voltage). Balancer is connected with its „+ batt.“ and „+ charg.“ connectors between charger and charged cells and when the voltage on cell sis increased above allowed limit (from any reason) it disconnects the charger and thus saves the cells from overcharging. Balancer indicates the disconnection by LED and beeper.

Be careful when connecting the charger and cell to these connectors. Connector „+ batt.“ must be connected to „+ pole of the charged cells“, connector „+ charg.“ to „+ pole of the charger“ ! It is not allowed to interchange connectors „+ batt.“ and „+ charg.“. If they are interchanged, charger will not be disconnected.

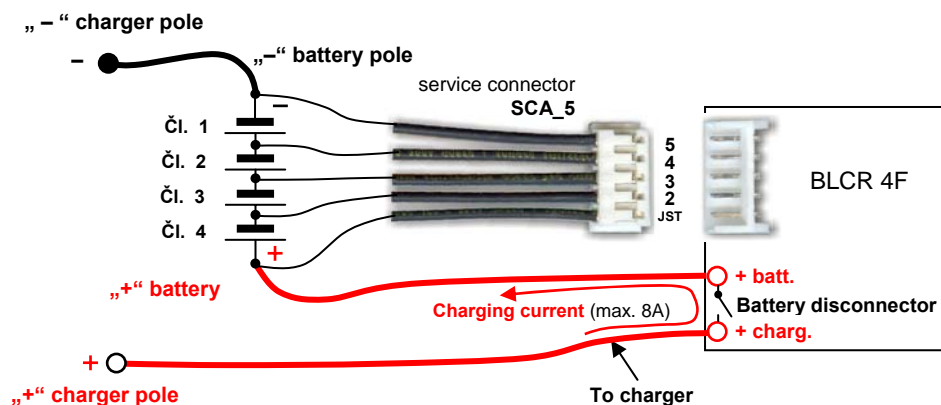
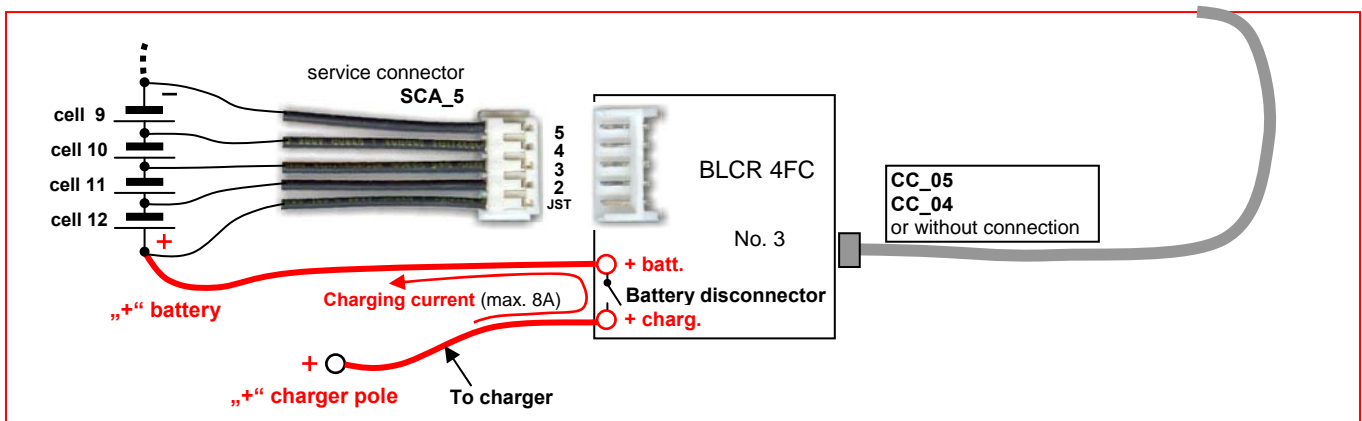

1. Setting of the end / switching off voltage (only when you need to change the value of end / switching off voltage):

- a) **standard Lipol (default)** – charging Lipol to **4.20 V** (ensured by charger) / safety switch off on 4.25 V
- b) constant current Lipol – charging Lipol to 4.18 V (ensured by charger) / safety switch off on 4.20 V
- c) standard Li-Ion – charging Li-Ion to 4.10 V (ensured by charger) / safety switch off on 4.15 V
- d) Li-Ion „A123 systems“ – charging Li-Ion to 3.60 V (ensured by charger) / safety switch off on 3.65 V

In case of mode **a)** and **c)** – operation with charger, the first value sets the estimated maximal charging voltage / cell supplied by the charger. Second value (after slash) gives the switching off voltage of the balancer. Short time exceeding of this voltage activates only LED and beeper, but when the voltage is exceeded permanently (*which should never happen with a quality charger – it is an error state*) acoustic as well as optical indication is activated, and the disconnecting contact disconnects the charger if this feature is used.

In case of modes **b)** and **d)** operation with source of constant current (to 1A) is expected. The first value sets the maximal charging current/cell and when this value is reached the balancer holds it. Second value (after slash) gives the switching off voltage of the balancer. Short time exceeding of this voltage activates only LED and beeper, but when the voltage is exceeded permanently (*which should never happen – it is an again an error state – usually too large value of charging constant current*) acoustic as well as optical indication is activated, and the disconnecting contact disconnects the charger if this feature is used.

Setting procedure:

- 1) plug the programming coupler “mode choice” to programming pins. With more balancers BLCR 4FC connected - do this only for MASTER balancer – other BLCR 4FC balancers automatically take the setting from MASTER balancer.
- 2) switch the balancer on by connecting it to service connector of the battery pack
- 3) wait for beep and blink of blue LED with longer pauses
- 4) the desired end voltage is set by taking out the coupler after the x^{th} beep and blink of **blue LED** (e.g. taking the coupler out after the 3rd beep = mode „Li-Ion 4.10 / 4.15V) the different mode choices are repeated with short pause until the coupler is taken out. Setting may be repeated or changed anytime (step 2 – 4). The set mode is saved even after switch of the balancer (disconnection of cells). If the desired mode is set, you may start charging.

N The set mode is permanently saved until the next possible change.

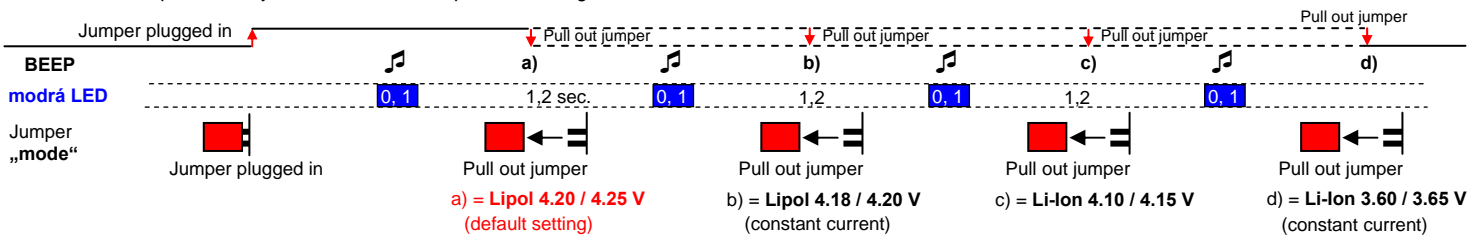

2. Indication of the set end / switching off voltage:

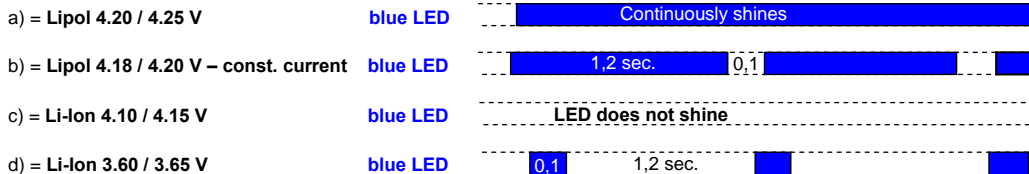

3. Indication after switch on:

- immediately after switch on, testing starts and all LEDs flash.
- short time after switch on (connecting the cells to balancer) the connected cells are indicated for ca 5 sec. by lit up corresponding green LEDs and also as many beeps as the number of connected cells will be heard.
- if in this time green LED of any cell is not lit up, the voltage of the cell is < 2V, the cell is missing or the wire / service connector is damaged !!! (**must be repaired !**)

After 5 seconds LEDs are turned off and balancing process starts. Intensity of brightness of particular **green LED** indicates its difference from the most charged cell. If the cells have similar voltages, LEDs are lit up with the smallest intensity. **These LEDs blinking in ca 1 sec. intervals for 0.25 sec. period - this indicates that everything is alright:**

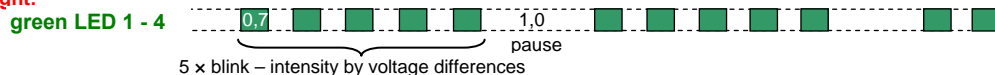

In consequence of the testing and possible communication can shortly blinking also other LEDs, no only LEDs corresponding with the connected cells. The intensity of **red LED ST** indicates limitations of balancing currents due to raised temperature. Also this LED turns of in ca 1sec. intervals. This LED without acoustic indication is only informative, is not of warning character.

4. Error indication:

- voltage of particular cell 1 to 5 is between 2.0 and 2.95V !!!
(cell is discharged too much !)



EMERGENCY ERROR WARNINGS !!! (USER INTERFERENCE NECESSARY):

- voltage of **some** cells exceeded set limits [V / cell]
(charging current are too high / cells are too different or defective
– **necessary to lower charging current**) - balancer is not sufficient to balance)
- voltage of **all** cells exceeded set limits [V / cell]
(charging currents are too high– **necessary to lower charging current**)
(charger is defective or incorrectly set – **must be turned off and repaired!**)
- overall voltage of cells < 6V (cell / cells are very undercharged)
- wait for the voltage to raise, **watch the process carefully!**

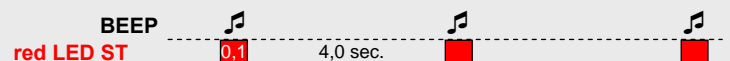
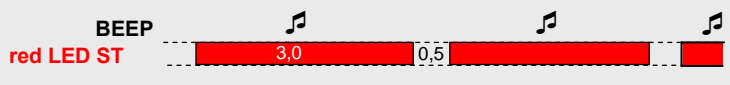

Recommended connections:

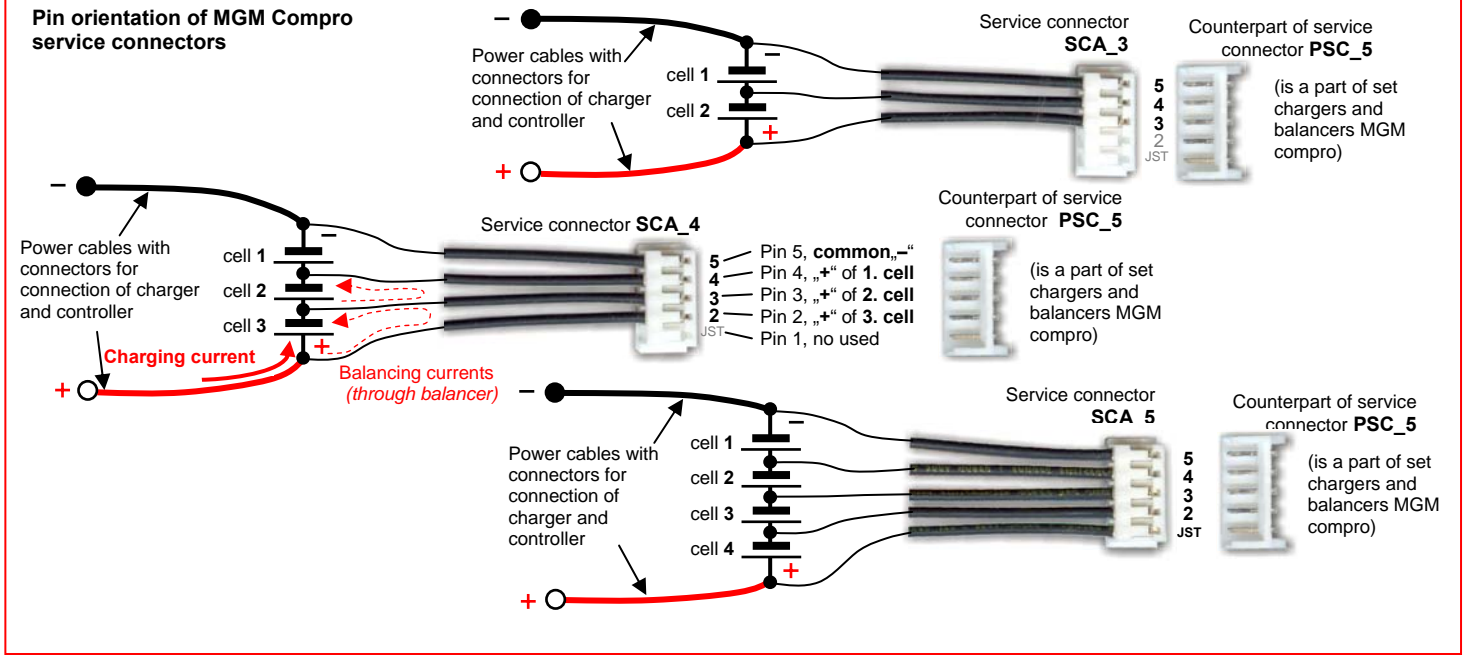

Charger Accessories:

Extension 5 pins service cable **PSCA_05**



SET_06 – provide connect Li-xxx battery with any service connector to MGM compro devices (AQCB xx or BLCR xx)

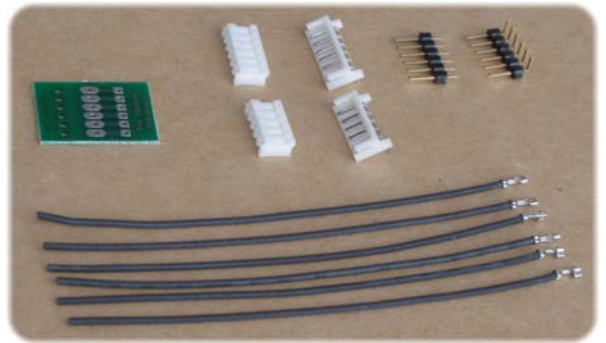

Service connector **SCA_2, SCA_3, SCA_4, SCA_5** with wires **100mm** or **300 mm** (SCA_5 / 100 mm on picture)



SET_02: cable 1,5 mm² + connectors **G3.5** + shrinking tube



Connection cable **CC_03:** connection **Charger / USBCOM+**

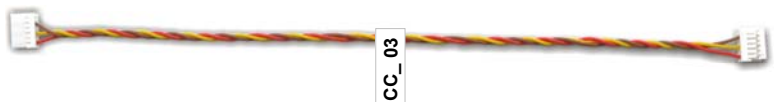

Connection cables **CHC 18, 25 or 35** with **MP JET** connectors 1.8 mm, 2.5 or 3.5 mm (for automatic battery disconnect)



Communication module **USBCOM+**



Connection cable **CC_05:** connection **balancer / module CM-3**



Connection module **CM-3**



Connection cable **CC_04:** direct connection **balancer / USBCOM+**

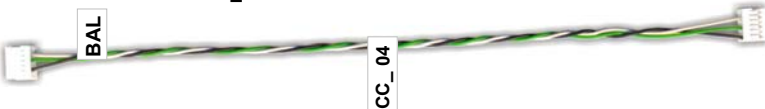

Outstanding features of BLCR 4F, BLCR 4FC version 2.50 and higher:

- a) compared to regular “balancers – voltage limiters” which do not truly balance but only limit the voltage on maximal value (e.g. 4.25V) BLCR 4FC truly and actively balance during the whole charging
- b) no settings needed, high accuracy is ensured by calibration during manufacture
- c) cells are balanced with accuracy in mV (less than 10mV)
- d) thanks to processor, it recognizes defective, damaged and undercharged cells, informs of error and emergency states
- e) permanent balancing from the very start of connection (also partially charged cells can be already balanced)
- f) may be used with all types of Lipol chargers (direct current as well as pulse) and current sources
- g) possibility of serial connection of balancers (using Cm-3 module) and possibility to balance up to 12 Lipol cells, BLCR 4FC only
- h) possibility of automatic disconnection when maximal set voltages are exceeded (from any reasons)
- ch) high balancing currents
- i) charging currents may be several times higher than balancing currents of balancer (applies for Li-xxx chargers not for sources of current!)
- j) reverse polarity protection
- k) small dimensions and weight
- l) non-interchangeable industrial connectors PSC_5 (for connection on service connectors SCA_3 up to SCA_5 used for battery packs)

Connection of the communication cable to the balancer, BLCR 4FC only. For details see manual „Charge Monitor control Dddmmyy“.



Correct orientation of connector: (flat part of connector top)



When cells are charged and balancer is disconnected a notice “balancing interrupted” appears. Charging history and graphs may be saved to file.

Example of balancing 12 Lipol cells, whole and detail. Charge slightly overcharges because a bit higher overall voltage 50.6 V was set (that is 4.215 V / cell). It is obvious that voltage of each cell is balanced in tolerance of ±6 mV and that from approximately 15th minute of charging. Then already balanced cells are charged.

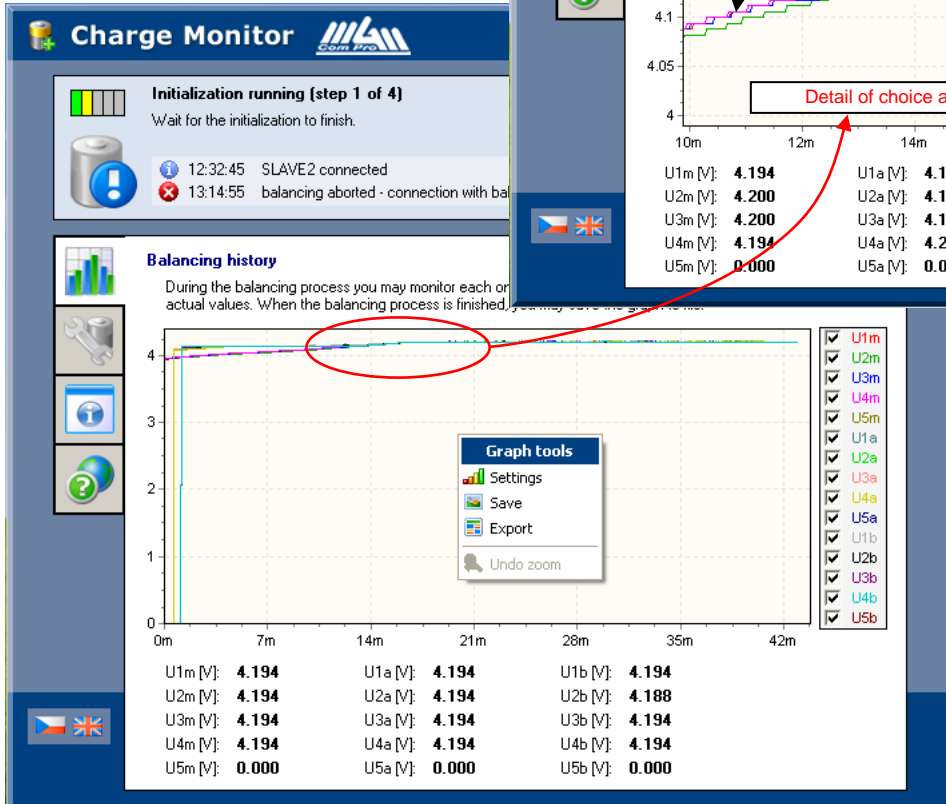
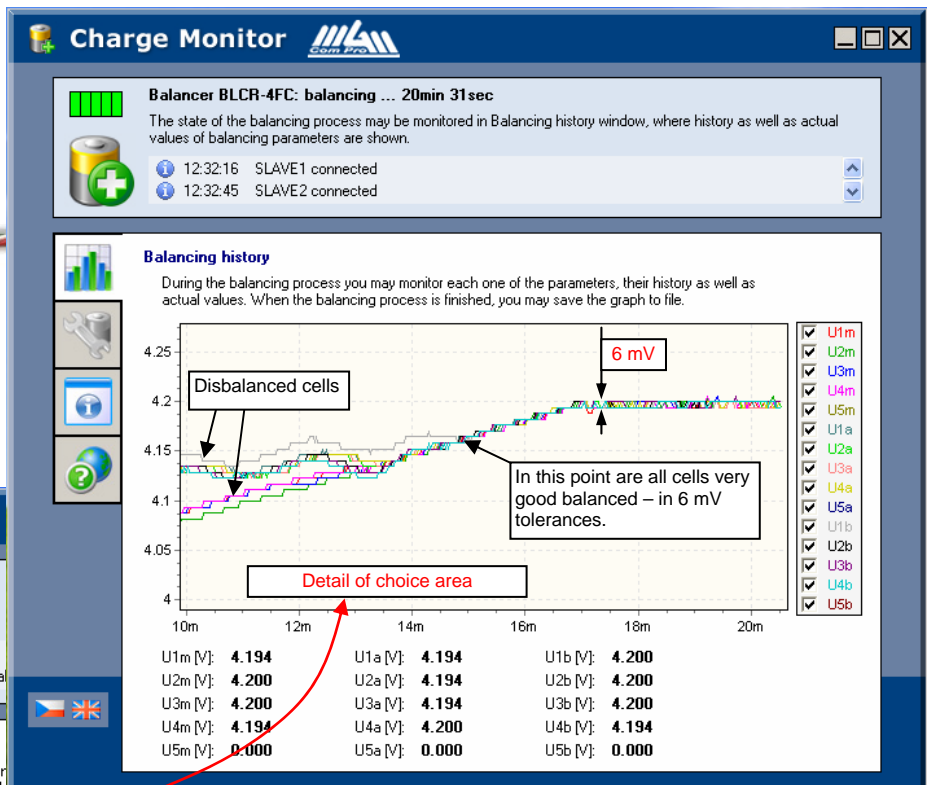

Voltage of cells connecting to balancer No 1. Voltage of cells connecting to balancer No 2. Voltage of cells connecting to balancer No 3.

