

These modules are designed for communication of controllers „EXPERT“ and „expert LT“, measuring device „Black Box“, and also possibly some other devices (such as chargers, etc) with PC equipped with Windows 98, Windows 2000 and Windows XP. Using module and appropriate SW for PC (Controller v X.xx) it is possible to program the above mentioned devices (program their parameters) and also read out actual data (from the last flight, etc). The module is connected to USB connector on PC and to servocable (instead of receiver) on controller or BB.

Type and version of controller is displayed automatically after connecting the controller and switching it on. Also the currently set controller parameters together with all necessary data (maximal current, maximal peak current, voltage of battery at the moment when switched off or temperature of controller – all data during last flight) are displayed. Each parameter can be easily and clearly set or changed according to your needs using mouse. Both, the read out data and parameters as well as new parameter settings can be saved in a file and then used again. The number of saved files is not limited.

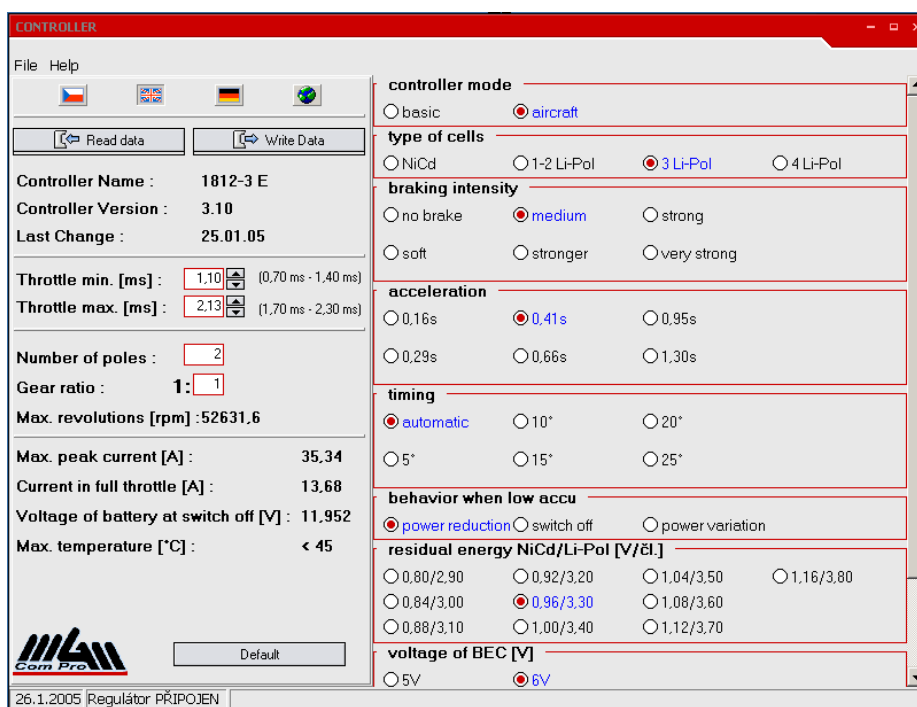

**Program installation:**

- 1) From the MGM compro CD copy (or download from [www.mgm-compro.cz](http://www.mgm-compro.cz)) the Controller.zip file to a new folder on hard drive of your computer. Then unzip file named „Controller.zip“ in the same directory (“extract here” choice). The directory will then contain the following:

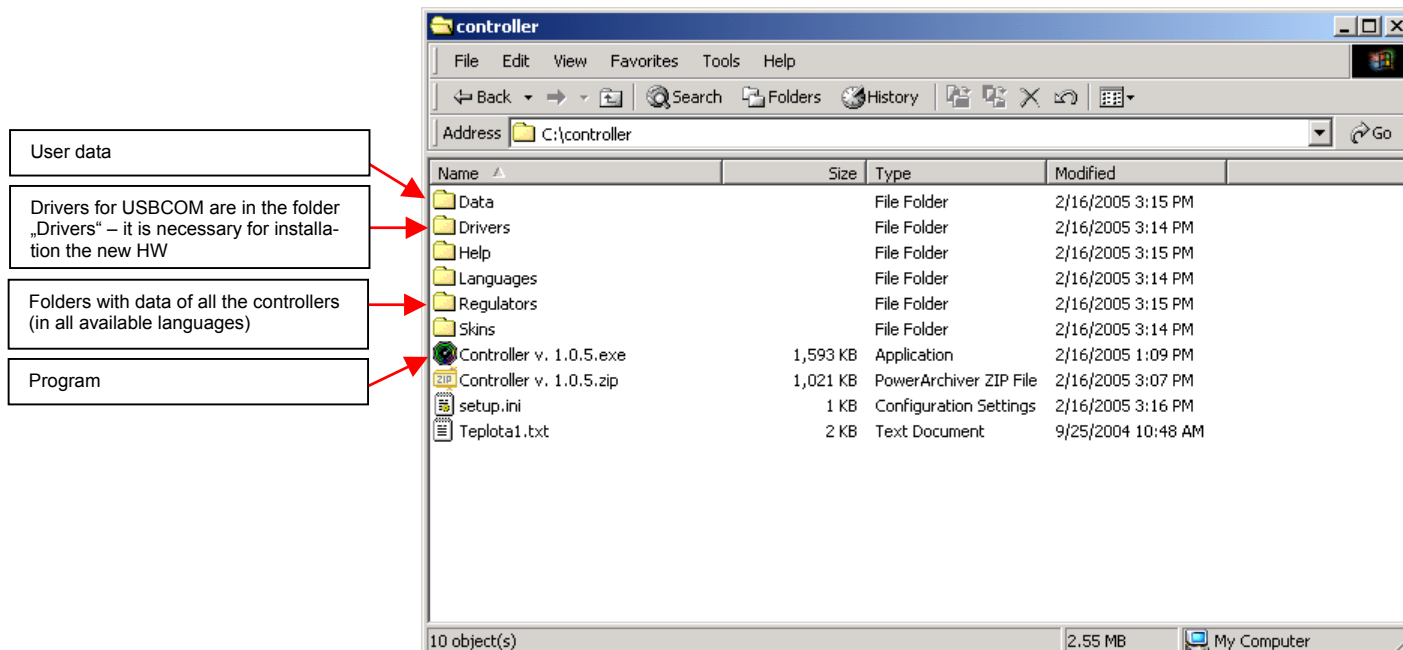

- 2) Connect USBCOM module to USB port of your computer and install necessary drivers (the computer will recognize new HW and will try to install drivers of FTDI) – those can be found in the directory „Drivers“ in folder „Controller“. It is possible that a restart of your computer will be necessary to continue.
- 3) Run „Controller v.1xx.exe“ program. You should see this window:

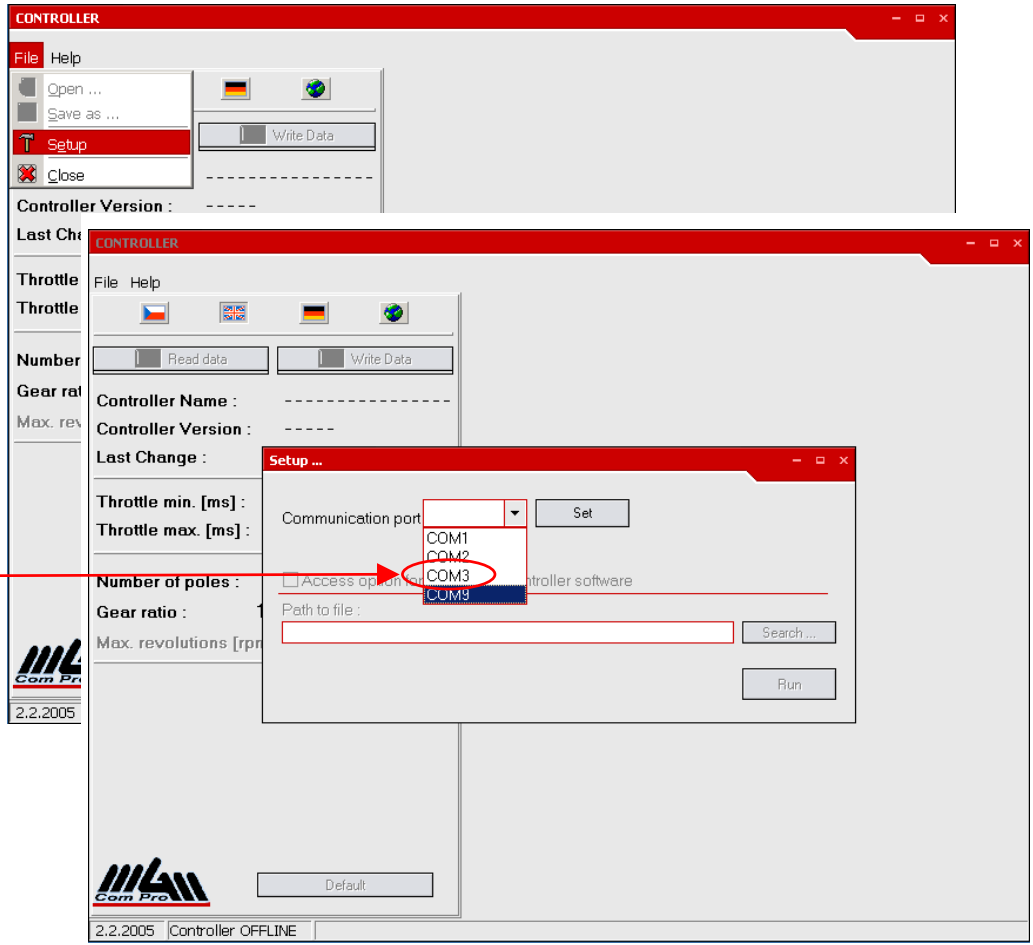

- 4) In menu File → Settings choose the serial line port which you wish to use for connecting the controller.

- 5) Press the „Set“ button and close this window. If a correct port was chosen, green LED will start to flash on the module. Installation is now finished. The number of the COM port can be found in the system setup, see below for more information.

How you find out the number of COM port for USB Serial Converter:

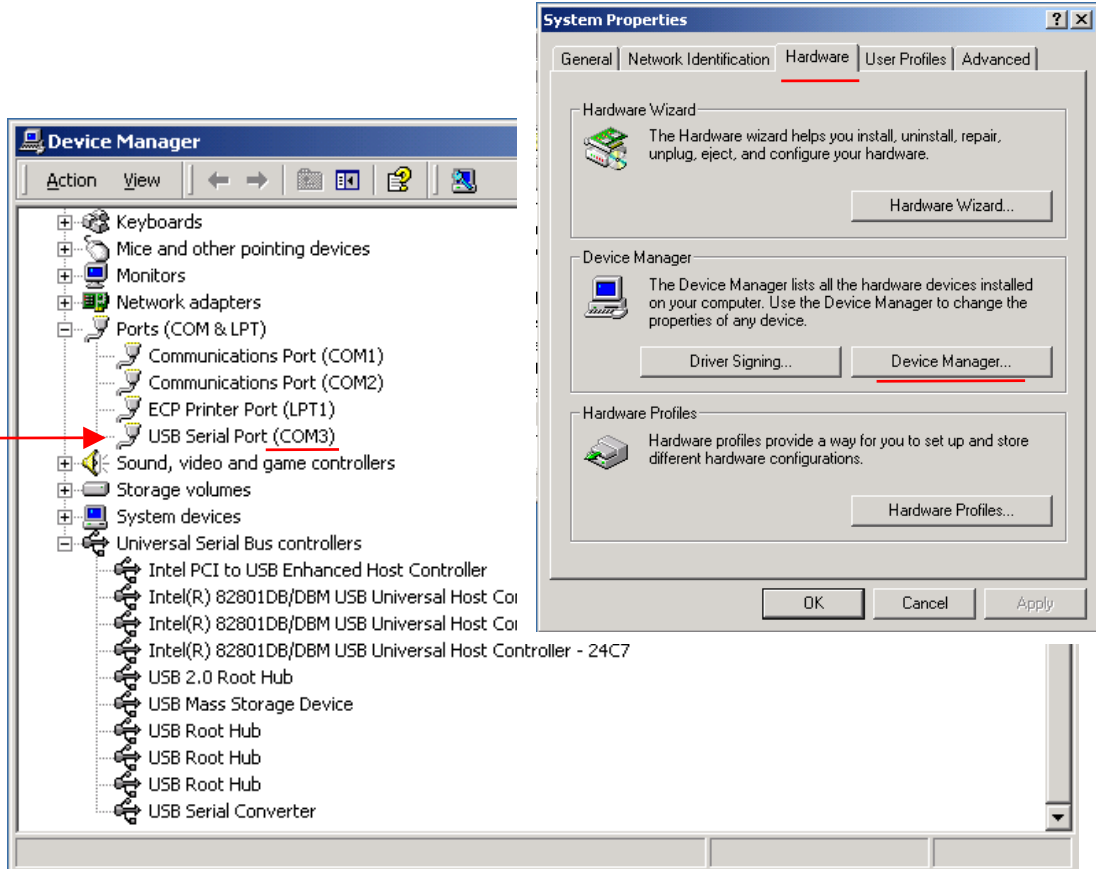

## Using the program:

- 1) connect the USBCOM module to USB port (if not yet connected)
- 2) connect the controller to the USBCOM module
- 3) run the Controller v.1xx.exe program; you should see this window:

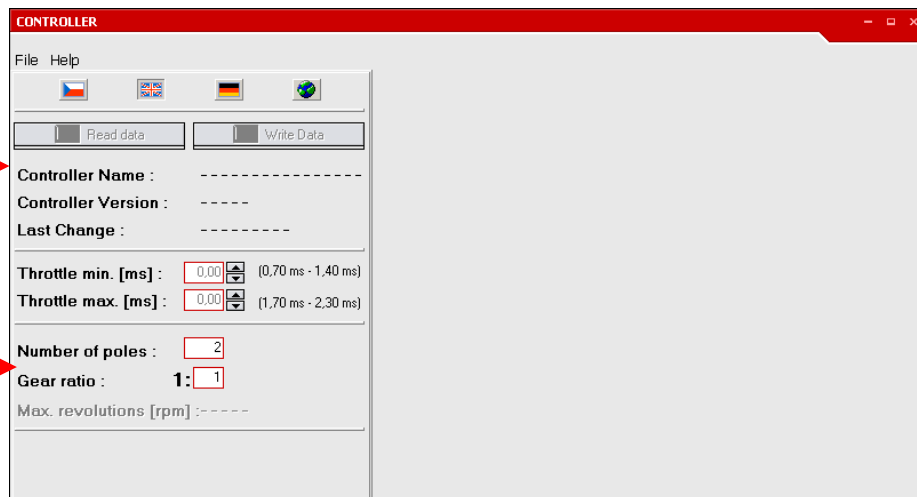

- 4) If you are interested in max. revolutions of the motor, or propeller, set number of poles of your motor and possibly also a gear ratio

- 5) connect batteries to the controller (see figure on page 4) and switch the controller on; 2 seconds later this window will pop up:

(it is not necessary to use the button „read out data“)

- Type and version of controller are recognized automatically
- Min. a max. throttle position – read out/ change of value
- Setting of number of motor poles and gear ratio

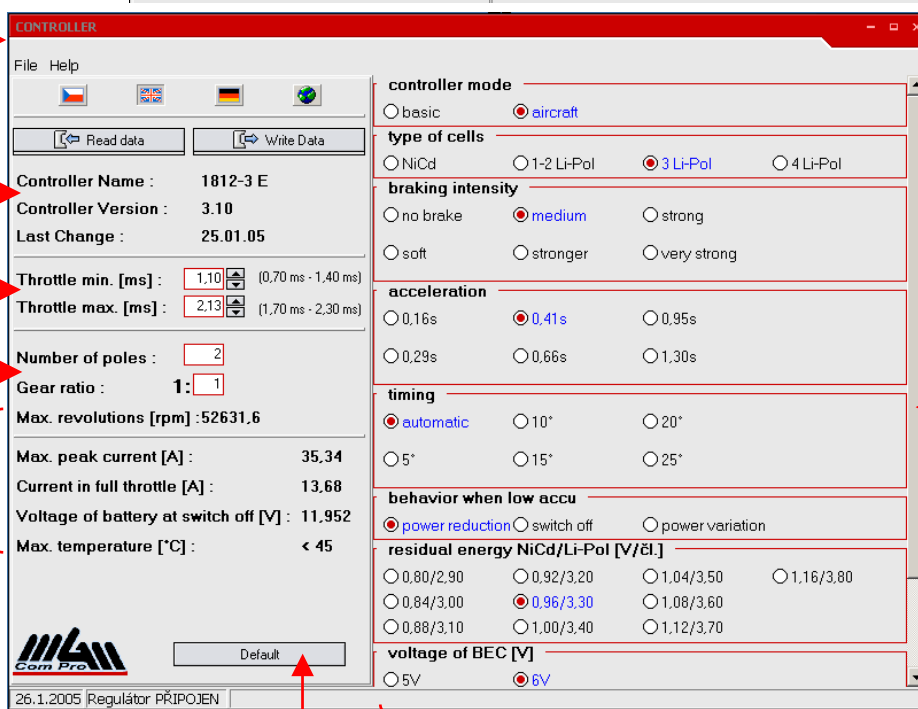

Measured values area

Fast setting of default parameters

Parameters read out from controller are displayed here + changes of parameters can be done here using mouse

Shift to other parameters

In this window, the name of the controller together with its SW version and all the programmable parameters and their actual values (same parameters as in the table in controller manual) will be displayed. If some of the parameters are displayed in gray, they are not available for that particular version of controller (or SW version). Possibly, they are not available in the chosen mode of controller (for example in basic mode it is not possible to change acceleration, timing, etc) – after switching to aircraft mode, these parameters will be available. All the settings may be saved in a file under any name, their number is not limited.

If instead of measured values are just dashes ( „-----“ ), the controller has not run for at least 2 seconds in full throttle and the value is not available.

Any programmable parameter can be changed using mouse. Then, all the changed settings as well as the read-out data can be saved in a file for later use (file → save as). To write data to controller simply press the „write data“ button. The default settings can be restored by the „Default“ button and then „write data“.

The possibility to find out the min and max throttle position can sometimes be very advantageous. These values can be set if needed using the appropriate buttons (arrows ▲ ▼).

When the programmable parameters are written to controller the data measured during the last flight are deleted. If now the read-out data button is pressed – data from the last flight will be empty („---“) and will be filled only after the next flight with the new parameters.

- 6) if further communication with controller is not required, switch it off and disconnect the servocable from USBCOM module. Close the program. Now, it is possible to disconnect USBCOM module from USB port.

To update only data files for controllers, it is enough to download just „DATA.zip“. If also SW (program „Controller“) is required to be updated, download the file „Controller.zip“. Both files are available for free at [www.mgm-compro.cz](http://www.mgm-compro.cz)

Meaning of each measured data:

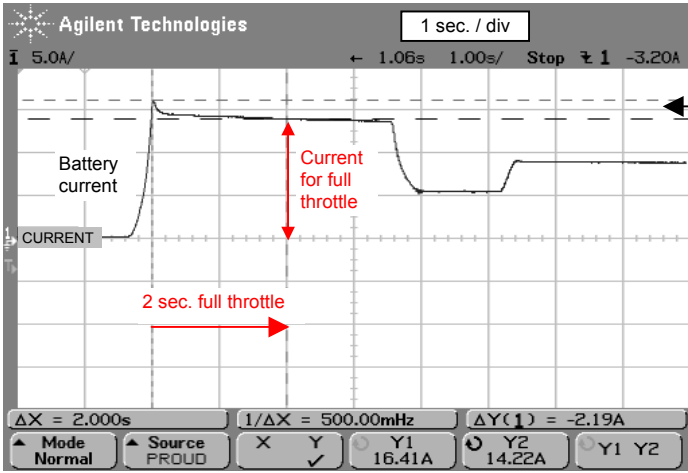

The value „Current in full throttle“ is the highest average value of current during the flight in stabilized state after 2 seconds in full throttle (therefore not the current overshoot when moving throttle stick quickly to full throttle).

The „Maximal current peak“ is the value of current peaks in PWM pulses – it should exceed 300% of nominal current in required mode (otherwise the current fuse will cut off). In the figure is show a case of motor start up – average current from battery is only ~ 3,8A, however the current peaks through FETs go as high as 21,9A (almost 6x times more as the average) !

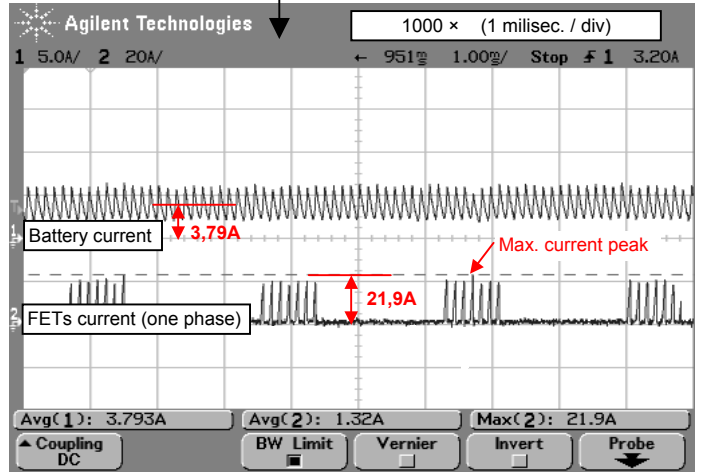

Both current values are considerably dependent on the temperature of the controller – they should therefore be considered only as a benchmark values for comparison measurements (for higher temperatures the current seems to be higher). **DOES NOT substitute for real Ampermeter !** The current fuse of the controller however takes care of this fact.

„Max. revolutions“ are maximal revolutions reached during the flight.

The „Voltage of battery when switched off“ shows the voltage at the moment when controller was switched off.

„Maximal temperature“ is the max temperature reached during the flight.

Connection BEC controller:

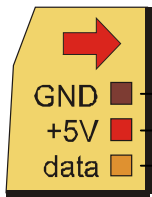

Line USB (to PC)

- Ground (minus), brown / black wire
- +5V, BEC voltage, red wire
- controll signal, orange / yellow

Supply battery



Servocable („Y“ cable) connect into USBCOM instead of receiver. Make sure, the servocable is connected correctly.

Connection OPTO controller:

In first step connect receiver battery. Controller switch on (or supply battery connect) in second step.

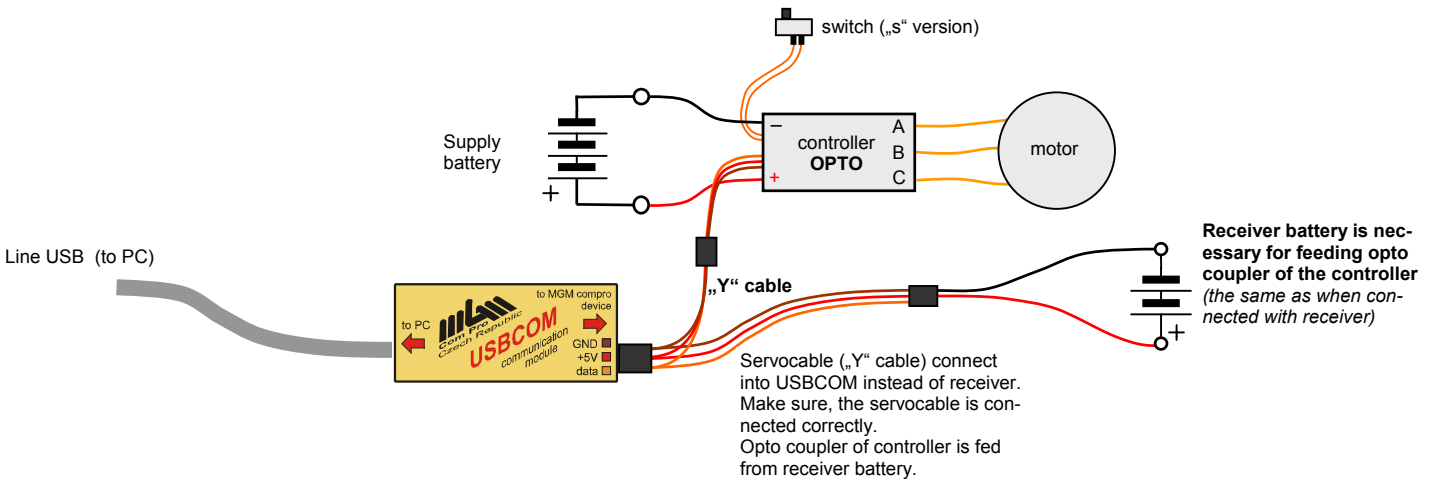

Receiver battery is necessary for feeding opto coupler of the controller (the same as when connected with receiver)

Servocable („Y“ cable) connect into USBCOM instead of receiver. Make sure, the servocable is connected correctly. Opto coupler of controller is fed from receiver battery.



Development, manufacture, service:  
MGM compro, Ing. G. Dvorský,  
Sv. Čecha 593, 760 01 Zlín, Czech Republic

Tel.: +420 577 001 350, fax: +420 577 001 348  
E-mail: mgm@mgm-compro.cz  
Info: www.mgm-compro.com