

Programmable DC controllers TMM[®] xx10 for brushed motors (Ver. 2.1x)

Controllers TMM[®] xx10 are outstanding programmable controllers for brushed motors. They are manufactured with the use of surface mounting from high-end components and are controlled by a very powerful processor. **Controllers must be set parameters by very simple process before first use. These parameters are then saved permanently.**

Thanks to the high-tech TMM[®] technology of MGM compro controllers feature number of outstanding properties which considerably eliminate the possibility of unwanted damage or destroy of motor, the batteries and the controller itself. Controllers also ensure the maximal efficiency with different kinds of motors.

Maximum attention is paid to development which is in continuous progress. To make our newest knowledge available to our customers the upgrade of SW is free (only shipping costs are charged).

The quality of products is under constant supervision in manufacture. Every controller goes through numerous tests. The final test of each controller is done under the controller's full load.

Protective and safety mechanisms of TMM[®] controllers:

Accumulators are protected in three ways. Firstly, due to the use of automatic current fuse (ACF) the current overload of accumulators (and their possible damage) even at crisis points can be avoided. Secondly, the used system of intelligent power reduce (IPR) always ensures through measurements of number of cells, voltage, currents, accumulator condition and calculations an optimal point of starting continuous reduction of motor performance (it is applied when accumulators become heavily discharged) so that accumulator cells do not get extremely discharged. This, not mentioning other advantages, reduces the possibility of reversal of poles of lower cells.

This system at the same time **enables retaining defined energy for BEC (perfect RPC)** in controllers that have BEC which is of great significance for flying models (a crash due to running out of energy for receiver and servos can be avoided) Thirdly, it is the automatic current reduce (ACR) due to which a drop in voltage for BEC under extremely big current load (for every given controller) while motor starts does not occur.

The controllers efficiently **mask interference and drop-outs** up to 1,5 sec. When long-lasting drop-outs or interference occur the controller slowly reduces motor revolutions. After the signal is resumed the controller continuously gets to the requested power. Without the proper signal from the transmitter (e.g. transmitter is turned off), the motor neither jerks nor runs but is at standstill.

Intelligent power reduce (IPR) and retaining enough energy for BEC (RPC)

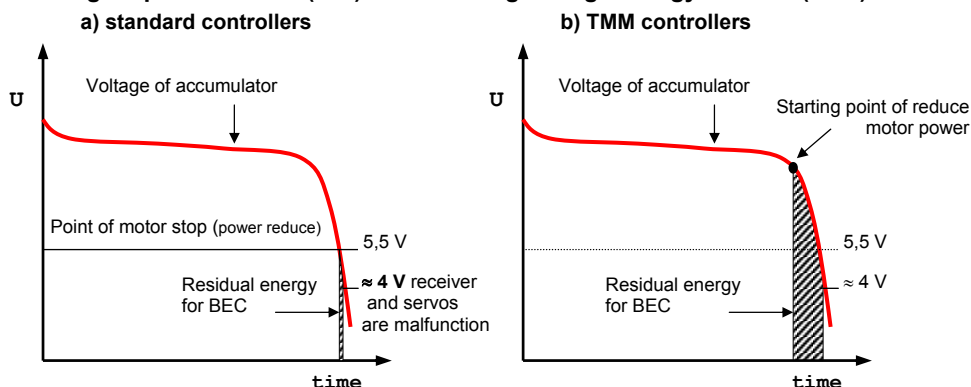

The controller's behavior at the point of exhausted batteries (or closely before that) is very significant from both the controlling point of view and economical use of remaining energy point of view.

When switching (reducing power) the motor off at solid boundary (a) there is only very little energy remaining for BEC, particularly for 8 or more cells in accu pack. The better accumulators are used the less energy (time) is left to land (standard ESC).

Comparing to this, TMM (b) ensures the remaining energy to be big enough; it is also possible to modify its size in some types (bigger for gliders). This energy is certainly insignificant as long as duration of running the motor is concerned, but it is very significant for feeding BEC.

Operating data:

Temperature of the environment: 0°C to 40°C
 Motor controlling: PWM 2 kHz
 Control signal: positive pulses 1,5 ± 0,5 ms, period 10 ÷ 30 ms
 User set parameters: brake on – off / NiCd, NiMH or Li-Ion, Li-Pol batteries / min and max throttle positions
 Automatically set parameters: number and quality of cells, controlling signal from transmitter, motor timing
 BEC: 5V / max. 2,0 A (power losses 2,5W continuous, 5W / 10 sec., etc., see graph)
 Suitable for motors: DC motors Mega, MIG, Model Motors, Potensky, Speed, Mabuchi apod, etc.

TMM [®]	0810L	0810	1210
Dimensions [mm]:	18×16,5×5	18×16,5×5	18×16,5×5
No. of feeding NiCd/NiMH cells:	4*) až 10	6 až 10	6 až 10
No. of feeding Li-Ion / Li-Pol cells:	2 to 3	2 to 3	2 to 3
Model:	BEC	BEC	BEC
Max. current (for full throttle):	8 A	8 A	12 A
Max. current for 5 sec.:	10 A	10 A	15 A
On-state switch resistance at 25 °C:	8,5 mΩ	8,5 mΩ	6,8 mΩ
Power conductors lenth/cross-section:	0,5 mm ²	0,5 mm ²	0,5 mm ²
JR gold connector, cables:	0,15 mm ²	0,15 mm ²	0,15 mm ²
Weight incl. all conductors ("s" version):	5 (6,8) g	5 (6,8) g	5 (6,8) g
Weight without power conductors ("s" ver.):	1,5 (3,2) g	1,5 (3,2) g	1,5 (3,2) g

*) **Note:** Controllers may be used also with 4 NiCd / NiMH cells which is requested by some modelers. However, feeding with such low voltage does not bring any big advantages (except possibly in some special cases). Proportionally bigger currents will be needed for keeping the same power. Losses grow with current squared (I²) therefore it is less favorable from the energetic point of view than feeding with more cells (and lower needed current). Moreover, it is not possible to ensure the stable BEC voltage of 5V which however does not interfere with many receivers and servos. When feeding from 4 and 5 cells the permitted limit currents are lowered 20%.

The appearance and operating data may be changed without prior notice

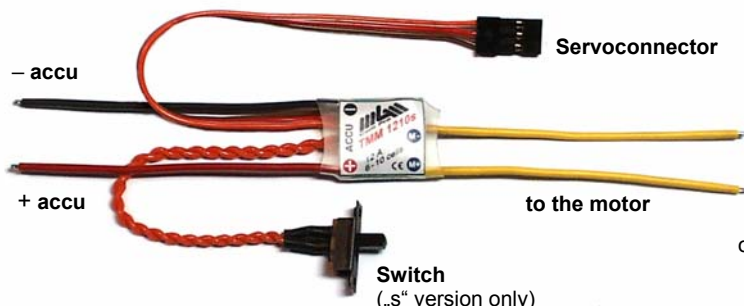

Note:

If you need to feed the receiver or servos from some other source carefully take out the central core of the servo cable connector. The taken out core of this conductor must be properly insulated.



Development, manufacture, servis:
 MGM compro, Ing. G. Dvorský,
 Sv. Čecha 593, 760 01 Zlín, Czech Republic

Tel.: +420 577 001 350, fax: +420 577 001 348
 E-mail: mgm@mgm-compro.cz
 Info: www.mgm-compro.com

BEC: controllers are equipped with BEC. The BEC can hold peak currents up to 2A and loss power loads which are significantly big but has its limits. It may not exceed 10W. It is possible to determine for example current which may be drawn from BEC under given load and voltage and also find out for how long from the graph. The power losses of the BEC warm the controller up. It is necessary to remove the generated heat by airflow. If the BEC is loaded with the power loss > 2,5W pauses for cooling are necessary so that the average power loss is ≤ 2,5W.

Power loss of BEC: $(U_{accu} - 5V) \times \text{current } I$

Example: (see graph) if voltage of batteries is 10,5V it is possible to draw current of 0,9A continuously for 10s when the power loss of BEC is 5W. If the load would only take 5 sec. the power loss may be 7,5W and it is possible to draw current up to 1,3A.

When exceeding the maximal limits of current or power losses, BEC may be destroyed and the model may be uncontrollable !

Please, notice that servos loaded with the control surfaces (rudder, ailerons etc.) in the air draw many times more current than when you move them on the ground !

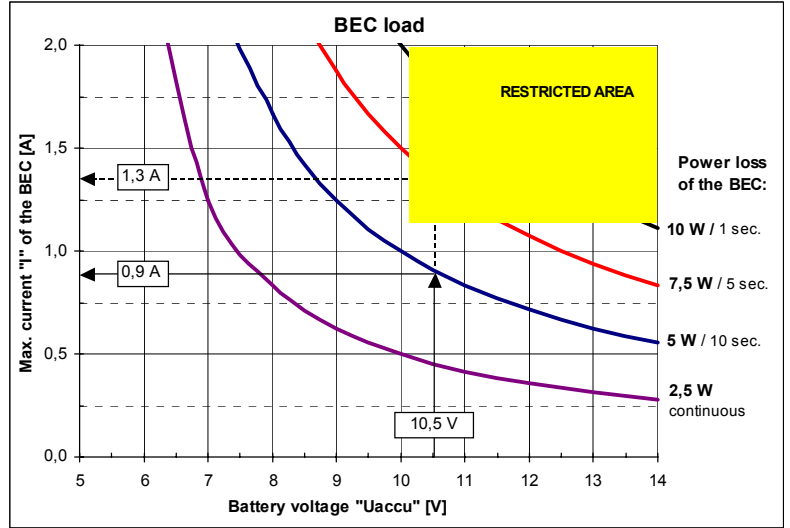

Instructions for use:

- Opposite piece of the connector, which is on your accumulators, should be soldered to the leading-in conductors to the accumulator. Use only quality golden plated kinds. We recommend the MP JET 1.8 mm or golden plated connectors Ø 2 mm. The MP JET connectors have considerable smaller contact resistance. We recommend to put socket on the “-“ wire (black wire) of the controller and the plug on the “+“ wire (red wire).
- Use power conductors as short as possible – it is better for minimum weight and for minimum interference. Receiver and antenna should be placed as far as possible from the controller, the batteries and power leads.
- **NOTICE, reversal of poles on wires to the batteries will destroy the controller !**
- The leads to the motor (yellow wires marked „M+“ a „M-“) should be soldered directly to the motor or it is also possible to use the connectors mentioned above. If you decide to use connectors, this time solder sockets to the controller leads !
Short cut of these wires together (when batteries are connected) or short cut of these wires to the feeding voltage results in damage or destroy of the controller !
- After the connectors are soldered it is necessary to isolate them, for example with heat shrinking sleeve ! (the connectors on pictures are without isolation sleeve for better clearness)
- If you need the motor to run in an opposite direction, swap wires to motor.
- **It is necessary to cool the controller in operation with flowing air. Do not prevent the cooling air to get to the controller (eg. by packing it in foam).**
- The controller informs of overload and overheating acoustically (motor beeping).
- The switch of the controller is connected in such way that even if it gets damaged the BEC will be still functioning.
The controller is switched on by TURNING OFF the switch (applies to “s” version with switch) or by connecting batteries (applies to versions without switch).
- **Do not switch off or disconnect the controller from batteries when motor runs or when it is still turning – that may lead to damage or destroyed of controller !!!**

CONTROLLER MUST BE PROGRAMMED

Error messages (the controller must be switched off to correct error, then switched on again):

- throttle stick was moved the opposite way then it is supposed to (the thrtolle stick was not in the min or max position at the beginning, and after beep it was moved to the max or min position to which the throttle was closer and not the other (correct way)
- low size of deflection of the throttle stick on the transmitter – you must shorten the size of deflection on transmitter
- overstep max. throttle position 0,5 and 2,5 ms – you must shorten the size of deflection
- switching on the controller with turned off transmitter
- more or less battery cells than specified
- current overload
(resumes operation after dropping throttle to zero, it is not necessary to switch the controller off in this case)

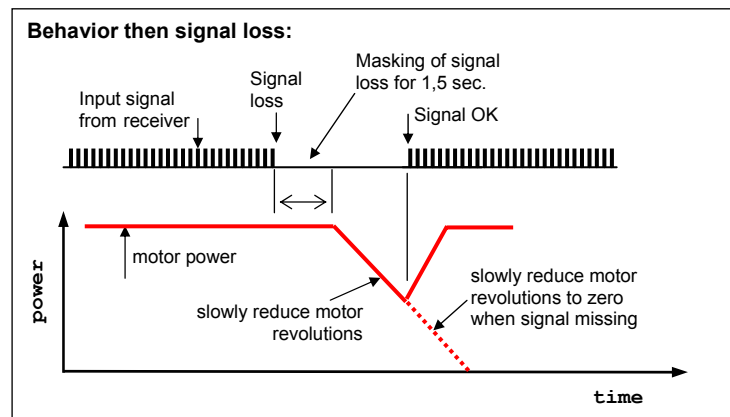
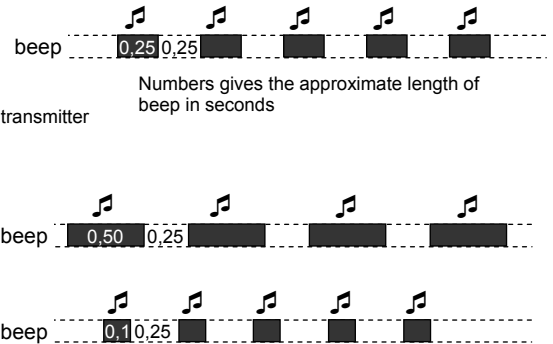

SETUP THE CONTROLLERS (PROGRAMMING):

All programming is done through transmitter and receiver with which the controller will run. After programming the data will be saved together with the min and max throttle positions (until possible next programming). It is necessary to switch the controller off afterwards to end the programming. When the controller is programmed it is ready for use immediately after switch on. **If after switching on, the throttle stick is not in the min position the controller waits for it to get there (safety precaution) – if the throttle is in its min position you may take off immediately.**

Description of parameters in the programming mode:

Parameter B – brake: enables to set the brake off or brake on. Set according to your needs.

Parameter C – type of cells: enables to set battery type which will use, Set according to your needs.

How to program the desired “value” in parameter you are setting (basic procedure in each parameter):

Move the throttle to ½ throttle motor beeps 2×. Move throttle back to min position motor beeps once. Repeat this procedure (½ throttle – min throttle) as many times as is the number of parameter (according to the table) you wish to set. **For example:** for setting the **number 2** in parameter “B” (brake on) repeat the whole procedure (½ throttle – min throttle) **2×** (you certainly have to be in parameter “B”).

The programming of each parameter will be finished when you move the throttle from min position to the full throttle – motor will beep 3×, then move the throttle back to min position, motor will beep once – the parameter is programmed to the value you have chosen and saved (**this sequence is marked as “ENTER”**). This also automatically gets you to next parameter. After the last programmed parameter the controller must be turned off.

If you do not wish to change some parameter (you wish to preserve its last value) you directly set full throttle when programming it (no ½ throttle – minimum procedure, but directly ENTER). The parameter value stay as it was before and the controller will get to the next parameter programming.

The programming itself:

1) Turn the transmitter on **with throttle stick in max position !**

Turn on **the controller**. After 10 seconds the controller will beep 3× and stay turned on. Now you have 3 seconds to move the throttle back to zero. If in this time limit you do not put the throttle in min position the programming process will end and the controller will be turned off. Its next operation is possible after turning it off with the switch and then turning on with switch (disconnecting and connecting of batteries).

If you put the throttle to zero in this time limit, the motor will beep 1×. Now you are in the programming mode and may start to program parameters according to the procedure described above.

2) parameter “B” – brake:

set according to the “How to program the desired “value” in parameter you are setting” (see above) set the desired value and move to next parameter by “Enter” sequence – also described above

3) parameter “C” – type of cells:

set according to the “How to program the desired “value” in parameter you are setting” (see above) set the desired value
By sequence „ENTER“ (set full throttle – back to min. throttle) you terminate programming. **Turn controller off !**

Parameter	Value of parameter →	0	1	2
B	Brake	next parameter	Brake off	Brake on
C	Type of cells	End of programming	NiCd / NiMH	Li-Ion / Li-Pol

WARNING:

You risk destroying the controller for:

- connecting more battery cells to the controller than the max. number specified in the technical data
- reversing connections to the accumulator
- shortcutting of wires to motor when batteries are connected
- changing motor and accumulator outlets
- overloading of the BEC with bigger currents or bigger power loss than is specified in technical data
- water in the controller (except for „hydro“ versions“)
- metal objects in the controller (screwdrivers, wires, etc.)
- disconnecting the controller from batteries or turning off the controller while motor is running (or still turning)

SECURITY WARNING:

Always disconnect the accumulators when not operating the model !!! Small current consumption occurs even when controller is switched off. Do not leave model with connected accumulators unattended ! Do not charge batteries when connected to the controller ! If the controller is connected to batteries do not stay in the reach of the propeller even when the controller is switched off ! Please notice that running motor with propeller is very dangerous !



PROGRAMMING TMM xx10

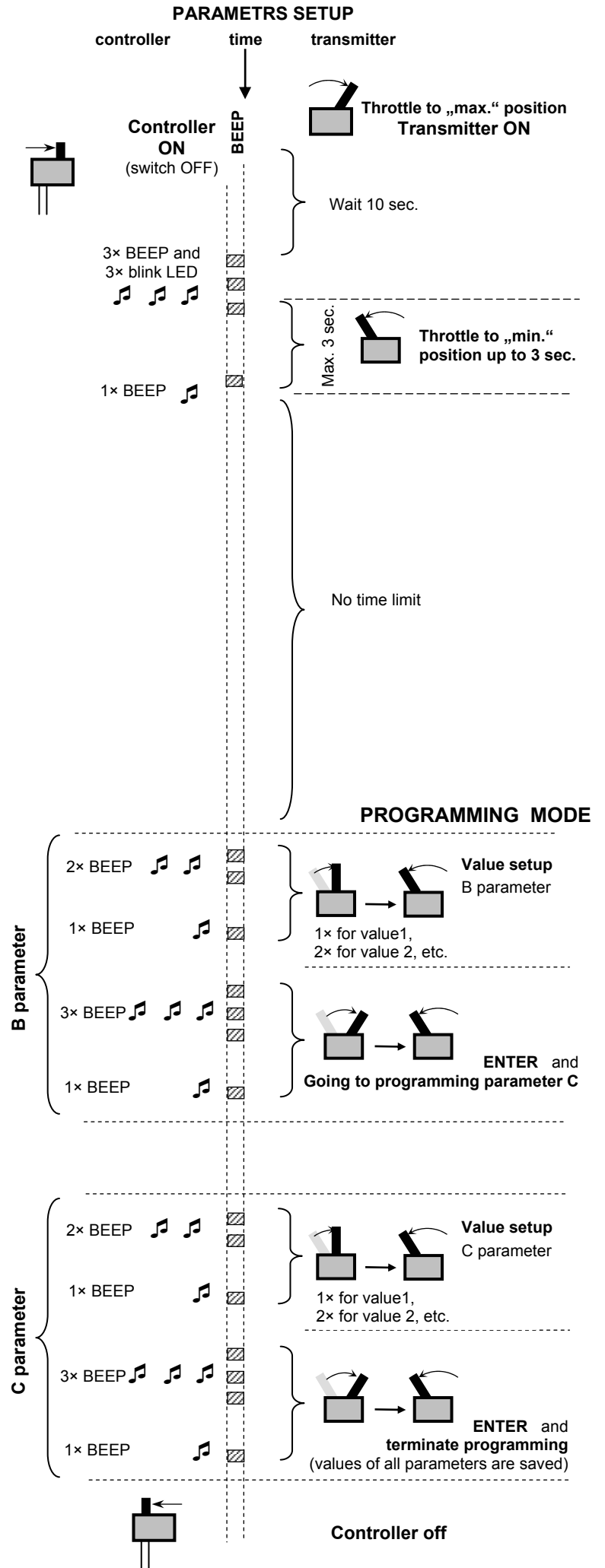
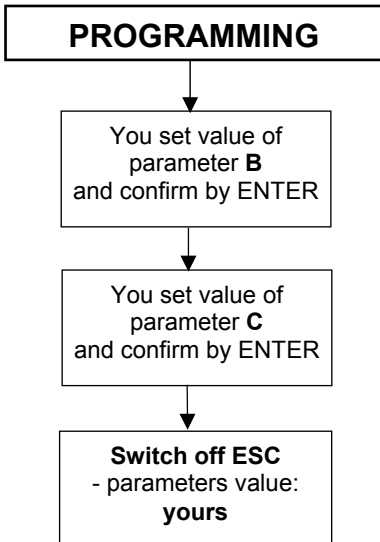

Legend:

